

SPECIFICATION SHEET

Power Ratings		kW	kVA
Power	Standby	56.0	70.0
	Prime	50.4	63
Amps 0.8 Power Factor 3-phase 208V		208	
12-wire voltages: 1P = 120/240; 3P = 120/208, 120/240, 480/277			

Rating Definitions: Rated for 1800 rpm.

Standby ratings are applicable for the duration of any power outage. No overload is available at these ratings. Prime ratings are continuous per BS 5514, DIN 6271, ISO3046 & IEC 34-1. Overload capacity on prime-power ratings is 10% for one hour in each twelve hours of operation. All single phase ratings are based on a 1.0 power factor, three (3) phase ratings based on a 0.8 power factor. Ratings are established based on 85°F (29°C) and an elevation of 1,000 feet (305 meters).

STANDARD FEATURES:

Tradewinds Power Corp (TPC) PERKINS diesel powered generator sets are UL2200 approved self contained standby generator packages complete with mounted auto control panel, fuel connector, air cleaners, exhaust silencers, and other accessories mounted on a rigid base frame. All TPC systems and components are prototyped, assembled and tested within a purpose built packaging, manufacturing, and test facility.

Engine:

- PERKINS model 1106D-E70TAG2 4-cylinder diesel engines designed to provide economic and durable operation at prime and standby duties, hitting the key power nodes required by the power generation industry.
- Building upon Perkins proven reputation within the power generation industry, the 1100 Series range of ElectropaK engines fit closely to customers needs
- These ultra clean engines are assembled on a new high technology production line. Frequent computerised checks during the production process ensure high build quality is maintained throughout.
- Oil and filter changes are 500 hours, dependent on load factor
- Wet steel sump with filler and dipstick
- Spin-on full-flow lub oil filter

Alternator:

- Marathon 4-pole, 12-wire brushless generator, single bearing
- Superior voltage waveform achieved by a 2/3 pitch and skewed rotor.
- Vacuum-impregnated windings with fungus-resistant epoxy for dependability and long-life
- Sustained short-circuit capability enabling down-line circuit breakers to trip without collapsing the generator field

Starting System:

- 12-VDC Starter
- Engine mounted Battery Charging Alternator
- Battery Cables and Rack along with Grounding Strap

Enclosure and Arrangement of Complete Assembly:

- Engine and generator close coupled on rigid frame with vibration isolators
- Vertical radiator and exhaust discharge
- Oil & Coolant Drain Lines with Brass Ball Check Valves

Generator Options:

- Weather Protective Enclosure constructed of Marine Grade Aluminum 0.125 thickness, SS Hardware, white powder coat paint finish on both sides, sound Insulation resistant to high temperatures, fuel and oil, hinged / removable / keyed alike doors
- UL double wall base mounted fuel tank
- Residential rated interior mounted exhaust silencer kit

STANDBY UL GENERATOR SET

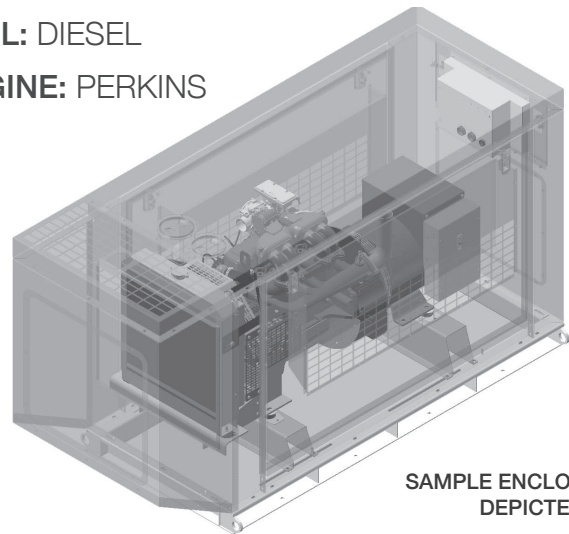
FUEL: DIESEL
ENGINE: PERKINS

**SAMPLE ENCLOSED SET
DEPICTED**
AUTOMATIC ENGINE CONTROLLER DGC2020:

- Automatic engine controller with analog display of all functions
- Microprocessor Based, Navigation key with large LCD display
- SAE J1939 CANBUS Communication
- Event Recording
- Transfer Switch Control (main failures)
- Alternator Protection: under/over voltage, under/over frequency
- Engine Protection: Low oil pressure, High coolant temperature, Over speed & over crank, Sender Unit failure, Fuel Failure sensor, Battery Charger Failure
- All protections are programmable as Alarms or Pre-alarms
- Metering (ample range): Volts, Current, Hz, Watts, VA, Pf, Oil Pressure, Coolant Temperature, RPM, DC Volts, Fuel Level, Engine running time
- Engine Control with Timers
- External remote start input (on or off load)
- 16 programmable contact inputs - 7 Contact outputs

SCADA interface points:

- No fuel
- Low battery charging voltage
- Engine running
- Common engine alarm
- Switch in Emergency Position

**DGC-2020 DIGITAL
CONTROLLER**
OPTIONAL CONTROL EQUIPMENT:

- Low coolant level switch
- Water separator fuel filter
- Space heater
- Generator drip covers
- 17-light remote annunciator panel

WARRANTY:

- Engine covered under the original equipment manufacturer's warranty - consult Tradewinds Power Corp for details
- Complete package supplied with 2-year limited warranty

The manufacture reserves the right to change the design or specifications without notice and without any obligation or liability whatsoever.

STANDBY UL2200 GENERATOR SET

ENGINE SPECIFICATION	
Manufacturer	Perkins
Model	1104D-E44TG1
Emissions	EPA Tier 3
Engine speed (rpm)	1800
Nominal Engine hp 1800rpm	96
Cylinder arrangement	4
Combustion system	Direct Injection
Aspiration	Turbocharged
Engine type	Diesel
Diesel Fuel Grade	ASTM D975 D2
Number of Cylinders	4
Displacement in ³ (liters)	269.0 (4.4)
Bore and Stroke inches (mm)	4.13 x 5.0 (105 X 127)
Cooling	Water-cooled
Governor	Electronic
Starting aids	Glow Plugs
Compression ratio	16.2:1
Air cleaner type	Medium duty dry type
Exhaust Silencer dBA	80dBA
Oil Filtration	Engine Mounted
COOLING SYSTEM FOR OPERATING AT 120° AMBIENT:	
Total coolant capacity gals (Liter)	4.3 (16.5)
Cooling System	Water-cooled
Radiator System	Engine Mounted
Maximum Allowable Oil Temperature F (C)	250 (121)
LUBRICATING SYSTEM:	
Total lubricating capacity quarts (Liter)	2.2 (8.4)
Oil consumption at full load	< 0.1% of fuel consumption
Recommended lubricating oil grade	SAE 15W40
Oil Filter	Full flow spin on, cartridge type

ENGINE ELECTRICAL SYSTEM:	
Starting motor voltage	12 volt
Charger	65 amp alternator with DC output
Wet Cell Battery	Lead Acid
ALTERNATOR:	
Configuration	Brushless, 12-wire, 4-pole
Frequency	60 Hz
Voltage regulation	+ / - 1%, V/Hz, Electronic, EMI filtered
No load to full load voltage regulation	+/- 2%.
Coupling	SAE Adapter, Flexible Disc, Direct
Bearing	Single
Manufacturer	Marathon
Model	283PSL1707
Load acceptance	One Step, 100% per NFPA 110
Compliance	NEMA, IEEE & ANSI for temp. rise
TIF Factor	Self ventilated drip-proof
FUEL CONSUMPTION: PER HOUR GALS (LITERS)	
100%	4.9 (18.7)
75%	3.4 (12.8)
50%	2.3 (9.0)
25%	1.4 (5.2)
CONTROL PANEL SPECIFICATIONS:	
Manufacturer (Model)	Basler (DGC-2020ES)
MPC-10 Controller Inputs	16
MPC-10 Controller Outputs	12
Operating power/consumption	6-32 VDC; Average load 14.2W
Communications	UL 508 R & CSA C22.2 #14
GENERATOR OPTIONS:	
Aluminum Enclosure	Sound attenuated to 68 dBA
Base arrangement	Rigid steel base frame with AVMs
Spill containment	UL double wall base mounted

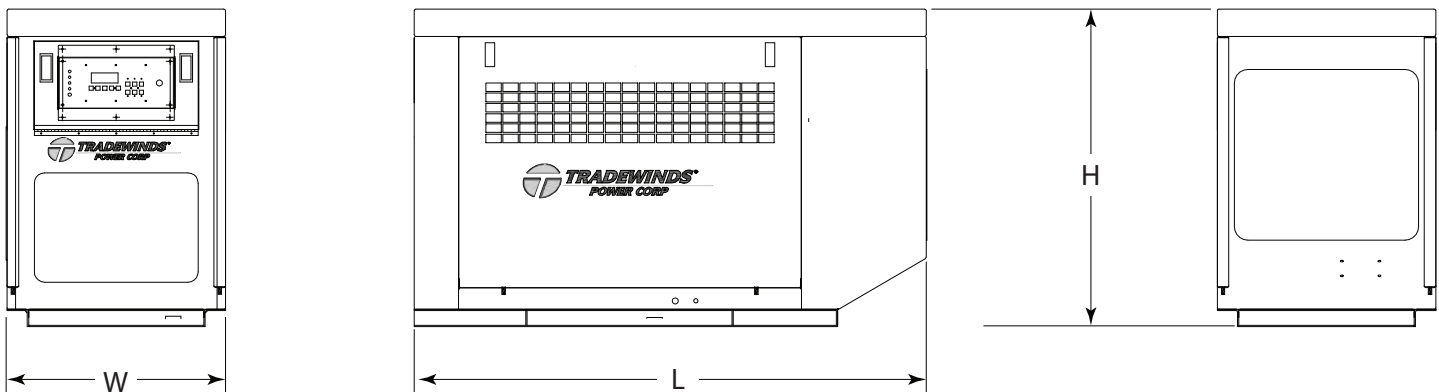
DIMENSIONS & ARRANGEMENT DRAWING UL2200 MODEL: TP56 T3

KEY DIMENSIONS (inches), WEIGHT (pounds) FUEL TANK (US gals)								
Description & Configuration	Height	Length		Width		Dry Weight lbs	Fuel Tank	
Open set	H1	50.00	L1	84.13	W1	36.00	2008	165
Enclosed Set	H2	66.00	L2	103.00	W2	36.00	2862	TBA