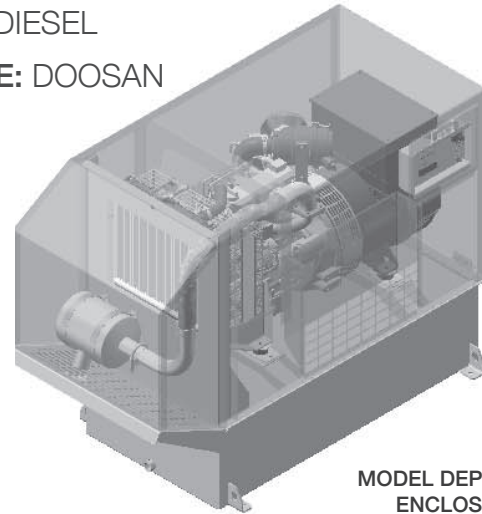

MOBILE DIESEL GENERATOR SET
FUEL: DIESEL
ENGINE: DOOSAN

**MODEL DEPICTED: TP14 T4F
ENCLOSURE OPTION**
SPECIFICATION SHEET

Power Ratings		kW	kVA
Power	Standby	9.0	9.0
	Prime	8.1	8.1
Ampage Unity PF	240V	38	
4-wire voltages: 1P = 120/240			

Rating Definitions: Rated for 3600 rpm.

Standby ratings is applicable for supplying emergency power for the duration of the utility power outage. No overload capability is available for this rating. A standby rated engine should be sized for a maximum of an 80% average load factor and 200 hours of operation per year. This includes less than 25 hours per year at the Standby Power rating. Ratings are established based on 85°F (29°C) and an elevation of 1,000 feet (305 meters).

STANDARD FEATURES:

Tradewinds Power Corp (TPC) Diesel Perkins powered mobile configured generator sets are self contained standby generator packages complete with mounted auto control panel, air cleaners, exhaust silencers, and other accessories mounted on a steel frame, with vertical radiator and exhaust discharge and oil & coolant drain Lines. All TPC systems and components are prototyped, assembled and tested within a purpose built packaging, manufacturing, and test facility.

Engine:

- Perkins model 403F-11G diesel engine
- EPA Tier 4 - Final & Stage IIIB
- Direct injection high pressure common rail @ 1800 bar
- Heavy duty rated for standby and continuous prime power operation
- Cooling system capable of operation at 120°F ambient
- The Perkins diesel is best in class for meeting the latest emission regulations.
- Naturally aspirated and efficient and compact power
- Low noise and vibration due to better combustion and engine balance
- Cleaner burn means no DPF and lower maintenance costs

Alternator:

- Stamford 4-pole, brushless, dedicated single phase winding 311
- Single bearing
- Class H insulation system utilizes an unsaturated polyester varnish for optimal insulation life and superior moisture protection. A tropical insulation is added for increased environmental protection
- Optimized electrical design with four-pole, brushless features, utilizes a 2/3 pitch winding to minimize harmonic distortion
- Vacuum-impregnated windings with fungus-resistant epoxy for dependability and long-life
- AVR fitted as standard, with this self-excited system the main stator provides power via the AVR to the exciter stator. The high efficiency semi-conductors of the AVR ensure positive build-up from initial low levels of residual voltage.

Starting System:

- 12-VDC Starter
- Engine mounted Battery Charging Alternator
- Battery Cables and Rack along with Grounding Strap

Factory Fitted Options:

- Weather Protective Enclosure constructed of Marine Grade Aluminum 0.125 thickness, SS Hardware, white powder coat paint finish on both sides, sound Insulation resistant to high temperatures, fuel and oil, hinged / removable / keyed alike doors, and 175mph wind load rating
- Double walled UL142 base mounted daily service fuel tank
- DOT road towing trailer

AUTOMATIC ENGINE CONTROLLER DGC2020:

- Automatic engine controller with analog display of all functions
- Microprocessor Based, Navigation key with large LCD display
- SAE J1939 CANBUS Communication
- Event Recording
- Transfer Switch Control (main failures)
- Alternator Protection: under/over voltage, under/over frequency
- Engine Protection: Low oil pressure, High coolant temperature, Over speed & over crank, Sender Unit failure, Fuel Failure sensor, Battery Charger Failure
- All protections are programmable as Alarms or Pre-alarms
- Metering (ample range): Volts, Current, Hz, Watts, VA, Pf, Oil Pressure, Coolant Temperature, RPM, DC Volts, Fuel Level, Engine running time
- Engine Control with Timers
- External remote start input (on or off load)
- 16 programmable contact inputs - 7 Contact outputs

SCADA interface points:

- No fuel
- Low battery charging voltage
- Engine running
- Common engine alarm
- Switch in Emergency Position

**DGC-2020 DIGITAL
CONTROLLER**
OPTIONAL EQUIPMENT:

- Low coolant level switch
- Water separator fuel filter
- Space heater
- Generator drip covers
- 17-light remote annunciator panel

WARRANTY:

- Engine covered under the original equipment manufacturer's warranty - consult Tradewinds Power Corp for details
- Complete package supplied with 2-year limited warranty

The manufacture reserves the right to change the design or specifications without notice and without any obligation or liability whatsoever.

ENGINE SPECIFICATION:	
Manufacturer	Perkins
Model	403F-11G
Emissions	EPA Tier 4
Engine speed (rpm)	1800
Nominal Engine hp 1800rpm	13.1
Cylinder arrangement	Vertical, in-line
Combustion system	Indirect Injection
Aspiration	Natural
Engine type	Diesel
Diesel Fuel Grade	ASTM D975 D2
Number of Cylinders	3
Displacement in ³ (liters)	69.0 (1.1)
Bore and Stroke inches (mm)	3.0 x 3.2 (77.0 X 81.0)
Cooling	Water-cooled
Governor	Electronic
Starting aids	Glow Plugs
Compression ratio	23.0:1
Air cleaner type	Medium duty dry type
Exhaust Silencer dBA	80dBA
Oil Filtration	Engine mounted
COOLING SYSTEM FOR OPERATING AT 120°F AMBIENT:	
Total coolant capacity gals (Liter)	1.4 (5.2)
Fan	Belt driven pusher fan
Radiator	Engine mounted
Cooling System	Water-cooled
LUBRICATING SYSTEM:	
Total lubricating capacity quarts (Liter)	1.3 (4.9)
Recommended lubricating oil grade	SAE 10W-30
Oil Pressure – psi (kPA)	90
Oil Filter	Full flow spin on, cartridge type

ENGINE ELECTRICAL SYSTEM:	
Starting motor voltage	12 volt
Charger	90 A Alternator with DC output
Wet Cell Battery	Lead Acid
ALTERNATOR:	
Configuration	Brushless, 12-wire, 4-pole
Frequency	60 Hz
Voltage regulation	+ / - 1%, V/Hz, Electronic, EMI filtered
No load to full load voltage regulation	+/- 2%.
Coupling	SAE Adapter, Flexible Disc, Direct
Bearing	Single
Manufacturer	Newage
Model	PI1445-311
Load acceptance	One Step, 100% per NFPA 110
Compliance	NEMA, IEEE & ANSI for temp. rise
Construction	Self ventilated drip-proof
FUEL CONSUMPTION: PER HOUR GALS (LITERS)	
Standby	T.B.A
Prime Power	0.74 (2.8)
75%	T.B.A
50%	403F-11G
CONTROL PANEL SPECIFICATIONS:	
Manufacturer (Model)	Basler (DGC-2020ES)
MPC-10 Controller Inputs	16
MPC-10 Controller Outputs	12
Operating power/consumption	6-32 VDC; Average load 14.2W
Communications	UL 508 R & CSA C22.2 #14
GENERATOR OPTIONS:	
Enclosure	Aluminum sound attenuated to 68 dBA
Base arrangement	Rigid steel base frame with AVMs
Spill containment	UL double wall base mounted

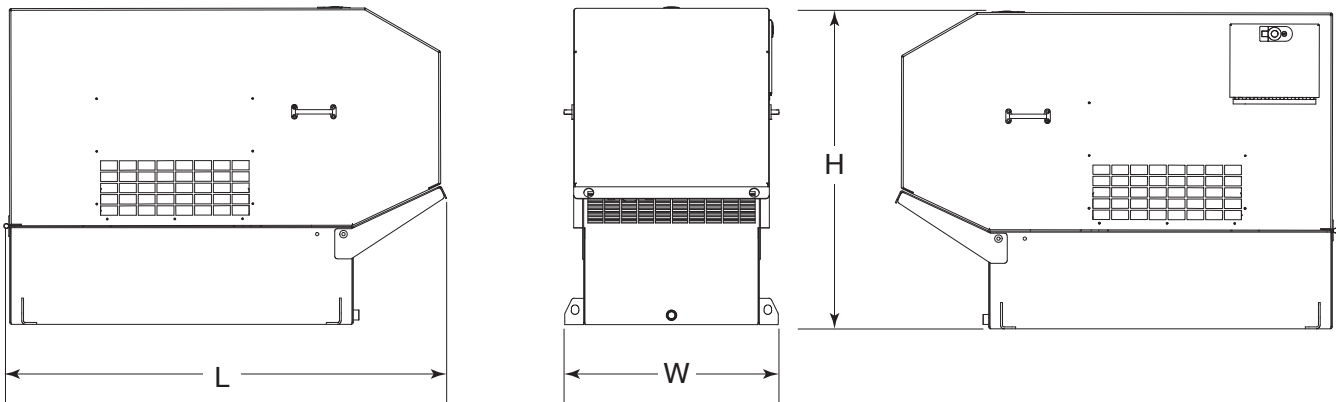
DIMENSIONS & ARRANGEMENT DRAWING MOBILE MODEL (WITH ENCLOSURE OPTION): TP9 T4i

KEY DIMENSIONS AND WEIGHT

Description	Height	Length	Width	Weight lbs (Kg)
Dimensions inches	42.06	57.31	28.38	867.5 (394.3)