

**MOBILE DIESEL GENERATOR SET**
**FUEL: DIESEL**
**ENGINE: DOOSAN**
**SPECIFICATION SHEET**

Power Ratings		kW	kVA
Power	Standby	20.0	20.0
	Prime	18.0	18.0
Ampage Unity PF	240V(120V)	83 (166)	
4-wire voltages: 1P = 120/240			

**Rating Definitions: Rated for 1800 rpm.**

Standby ratings is applicable for supplying emergency power for the duration of the utility power outage. No overload capability is available for this rating. A standby rated engine should be sized for a maximum of an 80% average load factor and 200 hours of operation per year. This includes less than 25 hours per year at the Standby Power rating. Ratings are established based on 85°F (29°C) and an elevation of 1,000 feet (305 meters).

**STANDARD FEATURES:**

Tradewinds Power Corp (TPC) Diesel Doosan powered mobile configured generator sets are self contained standby generator packages complete with mounted auto start controls, air cleaners, exhaust silencer, vibration isolators between assembly and feet, mounted radiator, muffler, and oil & coolant drain lines. All TPC systems and components are prototyped, assembled and tested within a purpose built packaging, manufacturing, and test facility.

**Engine:**

- Doosan model D18 diesel engine
- EPA Tier 4 - Final & Stage IIIB
- Direct injection high pressure common rail @ 1800 bar
- Heavy duty rated for standby and continuous prime power operation
- Cooling system capable of operation at 120°F ambient
- The Doosan 109.5 CID diesel is best in class for meeting the latest emission regulations. Exhaust after-treatment includes Diesel Oxidation Catalyst (DOC)
- Turbo-Intercooler for maximum efficiency and compact power
- Low noise and vibration due to better combustion and engine balance
- Cleaner burn means no DPF and lower maintenance costs

**Alternator:**

- Stamford 4-pole, brushless, dedicated single phase winding 311
- Single bearing
- Class H insulation system utilizes an unsaturated polyester varnish for optimal insulation life and superior moisture protection. A tropical insulation is added for increased environmental protection
- Optimized electrical design with four-pole, brushless features, utilizes a 2/3 pitch winding to minimize harmonic distortion
- Vacuum-impregnated windings with fungus-resistant epoxy for dependability and long-life
- AS480 AVR fitted as standard, with this self-excited system the main stator provides power via the AVR to the exciter stator. The high efficiency semi-conductors of the AVR ensure positive build-up from initial low levels of residual voltage.

**Starting System:**

- 12-VDC Starter
- Engine mounted Battery Charging Alternator
- Battery Cables and Rack along with Grounding Strap

**Factory Fitted Generator Options for Model TD20:**

- **Voltage selector switch:** 3-phase & 1-phase arrangements
- **Weather Protective Enclosure:** constructed of Marine Grade Aluminum 0.090 thickness, SS Hardware, white powder coat paint finish on both sides, sound Insulation resistant to high temperatures, fuel and oil, hinged / removable / keyed alike doors, and 175mph wind load rating, and sound attenuation 68dBA measured at 27ft
- **Fuel Tank:** Double walled UL142 base mounted daily service tank
- **Trailer:** DOT road towing
- **Battery Charge:** Fully automatic self adjusting to generator battery

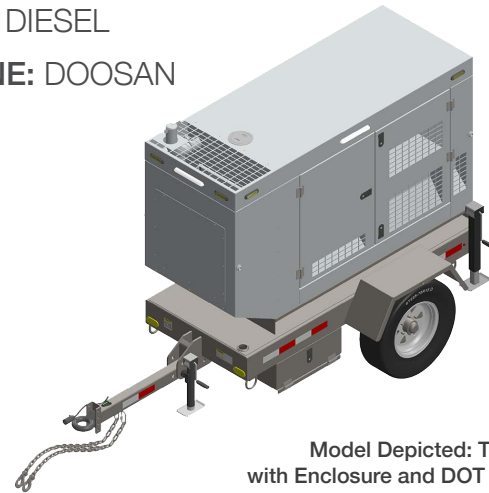

Model Depicted: TP20 T4F  
with Enclosure and DOT Trailer Options

**CONNECTION PANEL & CONTROLS:**

1. 2 x Receptacle 120V - 20A GFCI
2. 1 x Receptacle Twist Lock 50A 240V
3. Generator Controller DGC2020
4. 1 x Circuit breaker 2Pole - 20A
5. 2 x Circuit breaker 1Pole - 20A
6. 4 x Compression connector lugs

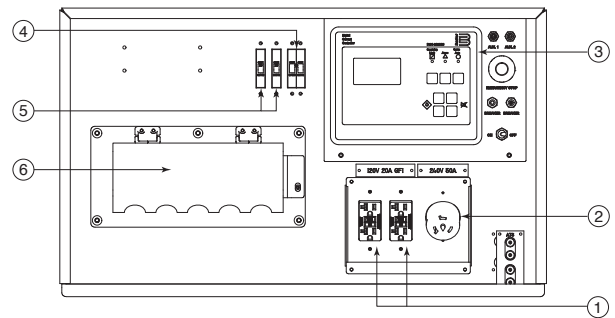
**AUTOMATIC GENERATOR CONTROLLER DGC2020:**

- Automatic generator controller with analog display of all functions
- Microprocessor Based, Navigation key with large LCD display
- SAE J1939 CANBUS Communication
- Event Recording
- Transfer Switch Control (main failures)
- Alternator Protection: under/over voltage, under/over frequency
- Engine Protection: Low oil pressure, High coolant temperature, Over speed & over crank, Sender Unit failure, Fuel Failure sensor, Battery Charger Failure
- All protections are programmable as Alarms or Pre-alarms
- Metering ( ample range ): Volts, Current, Hz, Watts, VA, Pf, Oil Pressure, Coolant Temperature, RPM, DC Volts, Fuel Level, Engine running time
- Engine Control with Timers
- External remote start input (on or off load)
- 16 programmable contact inputs - 7 Contact outputs

**SCADA interface points:**

- No fuel, Low fuel
- Low battery charging voltage
- Engine running
- Common engine alarm
- Switch in Emergency Position

**Optional Equipment:**

- Low coolant level switch
- 17-light remote annunciator panel
- Low coolant level switch

**WARRANTY:**

- Engine covered under the original equipment manufacturer's warranty - consult Tradewinds Power Corp for details
- Complete package supplied with 2-year limited warranty

The manufacture reserves the right to change the design or specifications without notice and without any obligation or liability whatsoever.

ENGINE SPECIFICATION:	
Manufacturer and Model	Doosan Model # D18
Emissions	EPA Tier 4 - Final & Stage IIIB
Engine speed (rpm)	1800
Max. (Cont.) HP Power 1800 rpm	39.54
Cylinder arrangement	In-line 3
Engine combustion system	Diesel Direct Injection
Aspiration	Turbo-intercooler
Fuel direct injection system (Diesel)	High Press. Com. Rail 1800 bar
Number of Cylinders	3
Displacement in <sup>3</sup> (liters)	109.48 (1.794)
Bore and Stroke inches (mm)	3.55 X 3.70 (90 x 94)
Cooling	Water-cooled
Governor	Electronic
Starting aids	Glow Plugs
Compression ratio	17.0:1
Air cleaner type	Medium duty dry type
Sound at 1m from engine block dBA	TBA
Max. Exh. Temp at full load degrees °F (°C)	932 (500)
Exhaust aftertreatment	Diesel Oxidation Catalyst (DOC)
COOLING SYSTEM FOR OPERATING AT 120°F AMBIENT:	
Cooling System	Water-cooled
Engine Coolant Capacity quarts (Liters)	3.48 (3.3)
Fan	Belt driven pusher fan
Radiator	Engine mounted
Eng. Cooling air flow - ft <sup>3</sup> /min (m <sup>3</sup> /min)	TBA
LUBRICATING SYSTEM:	
Total lubricating capacity quarts (Liter)	6.66 (6.3)
Recommended lubricating oil grade	SAE 10W-30
Oil Pressure – psi (kPA)	43.5 (300)
Oil Filter	Full flow spin on, cartridge type

ENGINE ELECTRICAL SYSTEM:	
Starting motor voltage	12 volt
Charger	90 A Alternator with DC output
Wet Cell Battery	Lead Acid
ALTERNATOR:	
Configuration	Brushless, Single Phase, 4-wire, 4-pole
Frequency	60 Hz
Voltage regulation	+ / - 1%, V/Hz, Electronic, EMI filtered
No load to full load voltage regulation	+/- 0.5%.
Coupling	SAE Adapter, Flexible Disc, Direct
Bearing	Single
Manufacturer	Stamford
Model	PI144E
Load acceptance	One Step, 100% per NFPA 110
Compliance	NEMA, IEEE & ANSI for temp. rise
Construction	Self ventilated drip-proof
FUEL CONSUMPTION: PER HOUR GALS (LITERS)	
100%	2.1 (7.9)
75%	1.61 (6.1)
50%	1.1 (4.3)
25%	0.69 (2.6)
CONTROL PANEL SPECIFICATIONS:	
Manufacturer (Model)	Basler (DGC-2020ES)
MPC-10 Controller Inputs	16
MPC-10 Controller Outputs	12
Operating power/consumption	6-32 VDC; Average load 14.2W
Communications	UL 508 R & CSA C22.2 #14
GENERATOR OPTIONS:	
Enclosure	Aluminum sound attenuated to 68 dBA
Base arrangement	Rigid steel base frame with AVMS
Spill containment	UL double wall base mounted

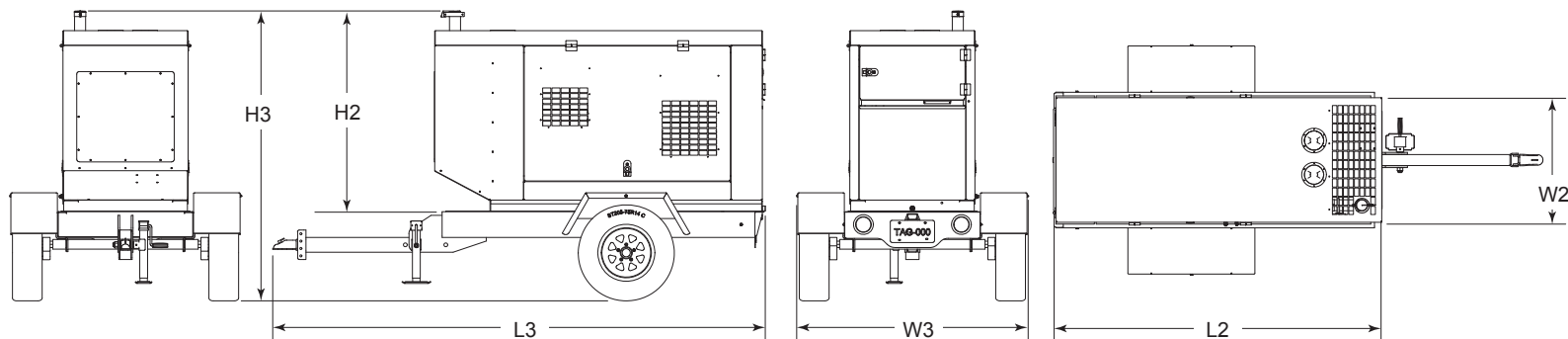
**DIMENSIONS & ARRANGEMENT DRAWING MOBILE MODEL (WITH DOT TRAILER & ENCLOSURE OPTION): TD20T4F**

KEY DIMENSIONS AND WEIGHT BASIC OPEN SET, SOUND ENCLOSURE AND MOUNTED ON DOT TRAILER (* = Option Equipment)									
Description ( inches)	Height	Width		Length		Dry weight lbs	Wet Weight lbs	Sound dBA	Fuel Tank Gals *
Open Set	H1	44.00	W1	36.00	L1	74.00	785	848	80
Enclosed Set *	H2	46.38	W2	34.00	L2	89.00	1167	1227	
Trailer mounted *	H3	73.35	W3	62.27	L3	132.13	2567	2645	