

MOBILE DIESEL GENERATOR SET
FUEL: DIESEL
ENGINE: PERKINS
SPECIFICATION SHEET

Power Ratings		kW	kVA
Power	Standby	500.0	625.0
	Prime	450	562.5
0.8 PF	240V	1505	
Single output Voltage Change Selector Switch: 120/240V, 120/208V, 277/480V			

Rating Definitions: Rated for 1800 rpm.

Standby ratings is applicable for supplying emergency power for the duration of the utility power outage. No overload capability is available for this rating. A standby rated engine should be sized for a maximum of an 80% average load factor and 200 hours of operation per year. This includes less than 25 hours per year at the Standby Power rating. Ratings are established based on 85°F (29°C) and an elevation of 1,000 feet (305 meters). (Generator rated & tested in 40°C ambient)

STANDARD FEATURES:

Tradewinds Power Corp (TPC) fully integrated Mobile power generator set, provides optimum performance, reliability and versatility. Efficiency matched heavy duty diesel engine, with an AC Synchronous, brushless, single bearing alternator. All TPC systems and components are prototyped, assembled and tested within a purpose built packaging, manufacturing, and test facility.

Engine:

- Perkins model 2806F-E18TAG1 diesel engine
- U.S. EPA non road (or off road) Tier 4 Final
- Aftertreatment technology with DOC, DPF, SCR/AMOX+DEF System
- Electronic high pressure common rail
- Heavy duty rated for standby and continuous prime power operation
- Cooling system capable of operation at 120°F ambient
- 2800 Series EP engines are a fully electronic fuel system for superior performance and low fuel consumption
- Series turbocharged aftercooled
- Hydraulic tappets, multi-vee belts, service free aftertreatment and 500 hour oil change intervals also keep your maintenance costs as low as possible

Alternator:

- Marathon Electric 4-pole, brushless, 12 leads AC alternator
- Double shielded and pre-lubricated single bearing
- Class H insulation UL1446 utilizes an unsaturated polyester varnish for optimal insulation life and superior moisture protection. A tropical insulation is added for increased environmental protection
- Optimized electrical design with four-pole, brushless features, utilizes a 2/3 pitch winding to minimize harmonic distortion
- Vacuum-impregnated windings with fungus-resistant epoxy for dependability and long-life NEMA MG-32, BS5000, IEC 34-1.
- Permanent Magnet Generator (PMG) Excitation with BE2000 voltage regulator.

Starting System:

- 24-VDC Starter
- Engine mounted Battery Charging Alternator
- Battery Cables and Rack along with Grounding Strap

Factory Fitted Generator Options for Model TP500:

- Voltage selector switch:** Single output 120/240V, 120/208V, 277/480V
- Weather Protective Enclosure:** constructed of Marine Grade Aluminum 0.125 thickness, SS Hardware, white powder coat paint finish on both sides, sound insulation resistant to high temperatures, fuel and oil, hinged / removable / keyed alike doors, and 175mph wind load rating, and sound attenuation 68dBA measured at 27ft
- Fuel Tank:** Double walled UL142 base mounted daily service tank
- Trailer:** DOT road towing heavy duty steel, hydraulic brakes, 12,000lb. cap. 2 spring axle, 7-way RV style plug, adjustable channel 6-Hole 5-position Military Hitch (3" lunette eye) coupler, 15" high side wind jack, and semi-gloss textured urethane UV resistant waterproof paint coating for protection against rust, corrosion, salt and damp conditions. .
- Battery Charge:** Fully automatic self adjusting to generator battery 6 Amp, 12 VDC, 90-265A AC 50/60Hz 115 VAC, compact type, UL Listed.

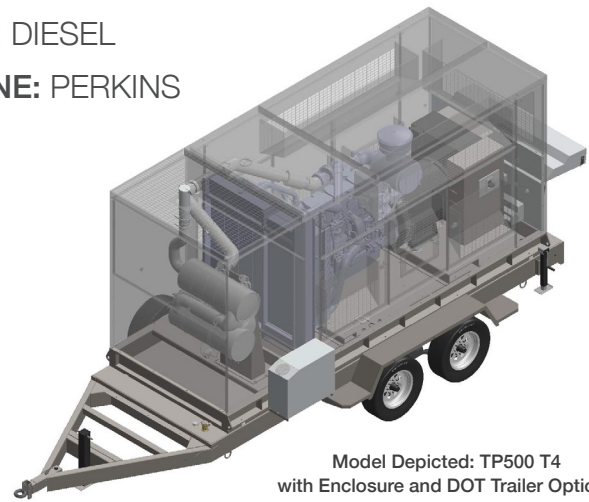

Model Depicted: TP500 T4
with Enclosure and DOT Trailer Options

CONNECTION PANEL & CONTROLS:

- 2000A rated CAM docking station 120/240V, 120/208V, 277/480V, female connectors with snap cover
- 2 x (2 x Receptacle 120V-20A duplex GFCI)
- 1 x Receptacle 30A 120V
- 1 x Receptacle 30A 240V
- 1 x Receptacle Twist Lock 50A 240V
- Terminal connection panel lid

Note: DGC 2020 controller within enclosure, & emergency stop mounted externally

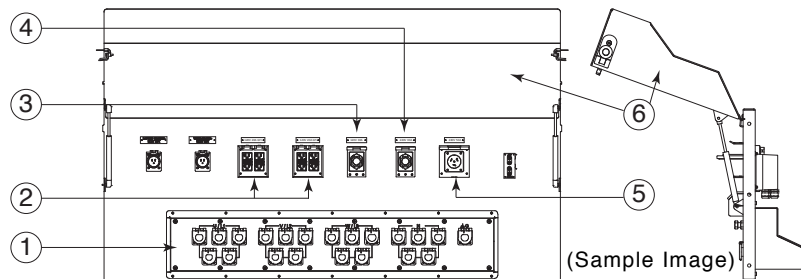
AUTOMATIC GENERATOR CONTROLLER DGC2020:

- Automatic generator controller with analog display of all functions
- Microprocessor Based, Navigation key with large LCD display
- SAE J1939 CANBUS Communication
- Event Recording
- Transfer Switch Control (main failures)
- Alternator Protection: under/over voltage, under/over frequency
- Engine Protection: Low oil pressure, High coolant temperature, Over speed & over crank, Sender Unit failure, Fuel Failure sensor, Battery Charger Failure
- All protections are programmable as Alarms or Pre-alarms
- Metering (ample range): Volts, Current, Hz, Watts, VA, Pf, Oil Pressure, Coolant Temperature, RPM, DC Volts, Fuel Level, Engine running time
- Engine Control with Timers
- External remote start input (on or off load)
- 16 programmable contact inputs - 7 Contact outputs

SCADA interface points:

- No fuel, Low fuel
- Low battery charging voltage
- Engine running
- Common engine alarm
- Switch in Emergency Position

Optional Equipment:

- Low coolant level switch
- 17-light remote annunciator panel
- Low coolant level switch

WARRANTY:

- Engine covered under the original equipment manufacturer's warranty - consult Tradewinds Power Corp for details
- Complete package supplied with 2-year limited warranty

The manufacture reserves the right to change the design or specifications without notice and without any obligation or liability whatsoever.

MOBILE DIESEL GENERATOR SET

ENGINE SPECIFICATION	
Manufacturer and Model	Perkins Model 2806F-E18TAG1
Emissions	EPA Tier 4
Engine speed (rpm)	1800
Max. (Cont.) HP Power1800 rpm	672
Cylinder arrangement	Vertical inline-6
Engine combustion system	Direct Injection
Aspiration	Turbo, air-to-air charge cooling
Fuel direct injection system (Diesel)	High pressure common rail
Number of Cylinders	6
Displacement in ³ (liters)	1104.5 (18.1)
Bore and Stroke inches (mm)	5.71 x 7.21 (145 x 183)
Cooling	Water-cooled
Governor	Electronic
Starting aids	Glow Plug
Compression ratio	16:1 1
Air cleaner type	Dry Type Replaceable Element
Sound at 7m from engine block dBA	109.9
Max. Exh. Temp at full load degrees °F (°C)	837 (447)
Exhaust aftertreatment Perkins CEM	DOC/DPF/SCR
COOLING SYSTEM FOR OPERATING AT 120° AMBIENT:	
Cooling System	Water-cooled
Engine Coolant Capacity quarts (Liters)	28.4 (26.9)
Fan	Belt driven pusher fan
Radiator	Engine mounted
Eng. Cooling air flow - ft ³ /min (m ³ /min)	13067 (370)
LUBRICATING SYSTEM:	
Total lubricating capacity quarts (Liter)	78.0 (74.0)
Recommended lubricating oil grade	SAE 10W-30
Oil Pressure – psi (kPa)	TBA
Oil Filter	Full flow spin on, cartridge type

ENGINE ELECTRICAL SYSTEM:	
Starting motor voltage	24 volt
Alternator charger Amps	85
Wet Cell Battery	Lead Acid
ALTERNATOR:	
Configuration	12-wire brushless rotating field
Frequency	60hz
Voltage regulation	PMG PM300
No load to full load voltage regulation	1/4% from no load to full load
Coupling	Flange to Flywheel Housing
Bearing	Single
Manufacturer	Marathon
Model	572RSL4027
Load acceptance	2/3 pitch design
Compliance	NEMA MG-1
TIF Factor	Shall not exceed 50
FUEL CONSUMPTION: PER HOUR GALS (LITERS)	
100%	37.0 (140.1)
75%	25.5 (96.7)
50%	18.3 (69.2)
25%	-
CONTROL PANEL SPECIFICATIONS:	
Manufacturer (Model)	Basler (DGC-2020ES)
MPC-10 Controller Inputs	16
MPC-10 Controller Outputs	12
Operating power/consumption	6-32 VDC; Average load 14.2W
Communications	UL 508 R & CSA C22.2 #14
GENERATOR OPTIONS:	
Enclosure	Aluminum sound attenuated to 68 dBA
Base arrangement	Rigid steel base frame with AVMS
Spill containment	UL double wall base mounted

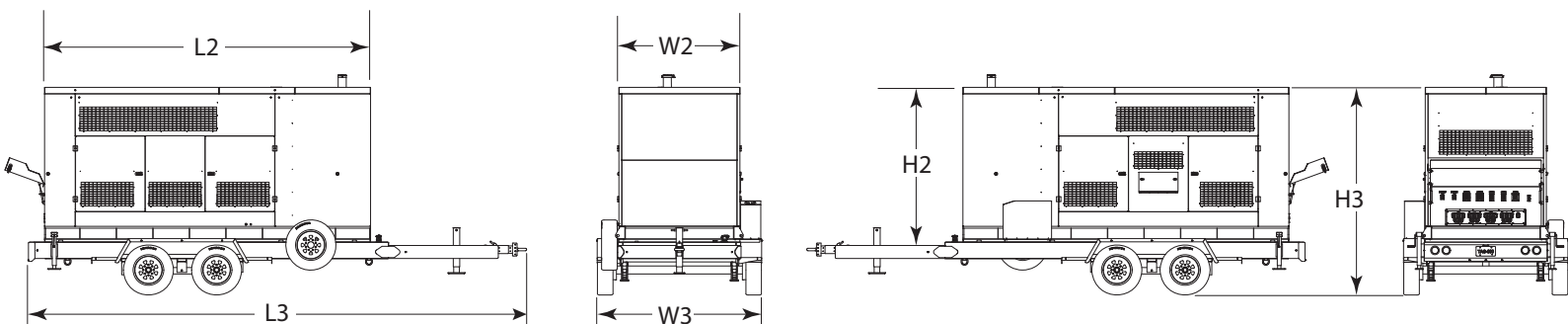
DIMENSIONS & ARRANGEMENT DRAWING MOBILE MODEL (WITH DOT TRAILER & ENCLOSURE OPTION): TP500 T4

KEY DIMENSIONS AND WEIGHT BASIC OPEN SET, SOUND ENCLOSURE AND MOUNTED ON DOT TRAILER (* = Option Equipment)

Description (inches)	Height	Width		Length		Dry weight lbs	Wet Weight lbs	Sound dBA	Fuel Tank Gals *	
Enclosed Set *	H2	95.75	W2	75.00	L2	201.85	10443	10673	68	500
Trailer mounted *	H3	128.5	W3	102.3	L3	292.75	16815	17045		