

MOBILE DIESEL GENERATOR SET
FUEL: DIESEL
ENGINE: PERKINS
SPECIFICATION SHEET

Power Ratings		kW	kVA
Power	Standby	80	125
	Prime	90	112
0.8 PF	240V	277	
Single output Voltage Change Selector Switch: 120/240V, 120/208V, 277/480V			

Rating Definitions: Rated for 1800 rpm.

Standby ratings is applicable for supplying emergency power for the duration of the utility power outage. No overload capability is available for this rating. A standby rated engine should be sized for a maximum of an 80% average load factor and 200 hours of operation per year. This includes less than 25 hours per year at the Standby Power rating. Ratings are established based on 85°F (29°C) and an elevation of 1,000 feet (305 meters). (Generator rated & tested in 40°C ambient)

STANDARD FEATURES:

Tradewinds Power Corp (TPC) fully integrated Mobile power generator set, provides optimum performance, reliability and versatility. Efficiency matched heavy duty diesel engine, with an AC Synchronous, brushless, single bearing alternator. All TPC systems and components are prototyped, assembled and tested within a purpose built packaging, manufacturing, and test facility.

Engine:

- Perkins model 1204F-E44TTAG2 1200 series diesel engine
- U.S. EPA non road (or off road) Tier 4 Final
- Aftertreatment technology with DOC and SCR
- Electronic high pressure common rail
- Heavy duty rated for standby and continuous prime power operation
- Cooling system capable of operation at 120°F ambient
- 1200 Series EP engines are a fully electronic fuel system for superior performance and low fuel consumption
- Series turbocharged aftercooled
- Hydraulic tappets, multi-vee belts, service free aftertreatment and 500 hour oil change intervals also keep your maintenance costs as low as possible

Alternator:

- Marathon Electric 4-pole, brushless, 12 leads AC alternator
- Double shielded and pre-lubricated single bearing
- Class H insulation UL1446 utilizes an unsaturated polyester varnish for optimal insulation life and superior moisture protection. A tropical insulation is added for increased environmental protection
- Optimized electrical design with four-pole, brushless features, utilizes a 2/3 pitch winding to minimize harmonic distortion
- Vacuum-impregnated windings with fungus-resistant epoxy for dependability and long-life NEMA MG-32, BS5000, IEC 34-1.
- Permanent Magnet Generator (PMG) Excitation with BE2000 voltage regulator.

Starting System:

- 12-VDC Starter
- Engine mounted Battery Charging Alternator
- Battery Cables and Rack along with Grounding Strap

Factory Fitted Generator Options for Model TP100:

- Voltage selector switch:** Single output 120/240V, 120/208V, 277/480V
- Weather Protective Enclosure:** constructed of Marine Grade Aluminum 0.125 thickness, SS Hardware, white powder coat paint finish on both sides, sound insulation resistant to high temperatures, fuel and oil, hinged / removable / keyed alike doors, and 175mph wind load rating, and sound attenuation 68dBA measured at 27ft
- Fuel Tank:** Double walled UL142 base mounted daily service tank
- Trailer:** DOT road towing heavy duty steel, hydraulic brakes, 12,000lb. cap. 2 spring axle, 7-way RV style plug, adjustable channel 6-Hole 5-position Military Hitch (3" lunette eye) coupler, 15" high side wind jack, and semi-gloss textured urethane UV resistant waterproof paint coating for protection against rust, corrosion, salt and damp conditions. .
- Battery Charge:** Fully automatic self adjusting to generator battery 6 Amp, 12 VDC, 90-265A AC 50/60Hz 115 VAC, compact type, UL Listed.

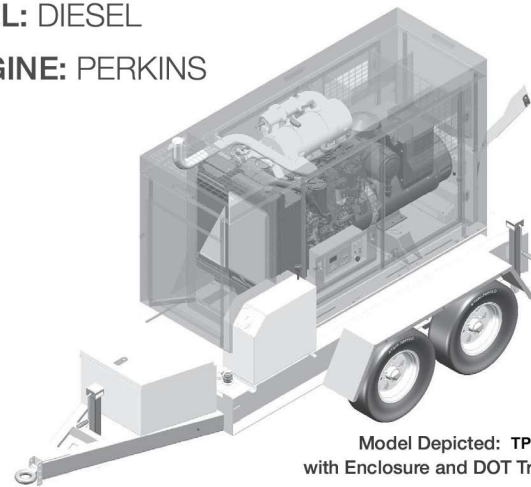

Model Depicted: **TP80 T4**
with Enclosure and DOT Trailer Options

CONNECTION PANEL & CONTROLS:

- 400A rated CAM docking station 120/240V, 120/208V, 277/480V, female connectors with snap cover
- 2 x (2 x Receptacle 120V-20A duplex GFCI)
- 1 x Receptacle 30A 120V
- 1 x Receptacle 30A 240V
- 1 x Receptacle Twist Lock 50A 240V
- Terminal connection panel lid

Note: DGC 2020 controller within enclosure, & emergency stop mounted externally

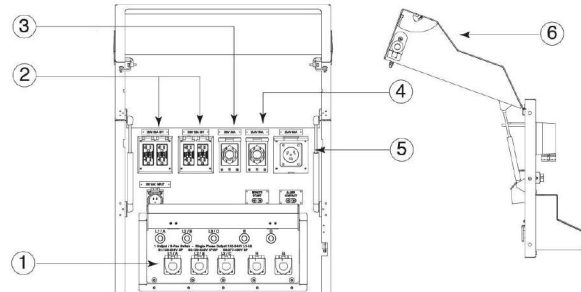
AUTOMATIC GENERATOR CONTROLLER DGC2020:

- Automatic generator controller with analog display of all functions
- Microprocessor Based, Navigation key with large LCD display
- SAE J1939 CANBUS Communication
- Event Recording
- Transfer Switch Control (main failures)
- Alternator Protection: under/over voltage, under/over frequency
- Engine Protection: Low oil pressure, High coolant temperature, Over speed & over crank, Sender Unit failure, Fuel Failure sensor, Battery Charger Failure
- All protections are programmable as Alarms or Pre-alarms
- Metering (ample range): Volts, Current, Hz, Watts, VA, Pf, Oil Pressure, Coolant Temperature, RPM, DC Volts, Fuel Level, Engine running time
- Engine Control with Timers
- External remote start input (on or off load)
- 16 programmable contact inputs - 7 Contact outputs

SCADA interface points:

- No fuel, Low fuel
- Low battery charging voltage
- Engine running
- Common engine alarm
- Switch in Emergency Position

Optional Equipment:

- Low coolant level switch
- 17-light remote annunciator panel
- Low coolant level switch

WARRANTY:

- Engine covered under the original equipment manufacturer's warranty - consult Tradewinds Power Corp for details
- Complete package supplied with 2-year unlimited warranty

The manufacture reserves the right to change the design or specifications without notice and without any obligation or liability whatsoever.

