

SPECIFICATION SHEET

Fuel	Rating	kW	kVA
DIESEL	Intermittent	100.0	100.0
	Continuous	90	90
AMPERAGE	240 volt	417	
Ratings for Single Phase Unity PF 120/240 Volts			

Rating Definitions: Rated for 1800 rpm.

Intermittent - Applicable for a varying intermittent loads with no overload capability.
 Continuous - Continuous prime rating is applicable for supplying power to a varying load for an unlimited amount of running time, with 10% overload capacity available for 1 out of every 12 hours.

STANDARD FEATURES:

Tradewinds Power Corp agricultural generator sets are designed, packaged, and tested to meet the power requirements of a wide range of equipment used in agricultural applications. All our systems and components are prototyped, assembled and tested within a purpose built packaging, manufacturing, and test facility.

Key System Features are:

- Rugged industrial diesel engine
- EPA certified for Agricultural use
- Unit designed to fit through 48 inch door opening
- Assembled on integral sub-base with lifting eyes
- Self contained with mounted exhaust and air-cleaner
- Heavy duty exhaust muffler
- Analog control panel
- 15-feet of fuel feed and return rubber hose

Engine:

- Perkins 1104D-E44TAG2 diesel engine
- Heavy duty rated for continuous prime power operation
- Cooling system capable of operation at 120°F ambient
- The 1104D utilizes the latest diesel mechanical controlled fuel system technology. This allows the 1104D-E44TAG2 to deliver high power density and excellent fuel economy with low exhaust emissions and minimum heat rejection
- The 1104D has been designed to be worldwide fuel tolerant, and 5% bio-fuel (RME) options are available to meet local market needs
- Mounted air filter and turbocharger
- Wet cast iron sump with filler and dipstick

Alternator:

- Marathon 4-wire brushless generator
- Wound for high motor starting capability
- Single phase, 120/240 volt

Arrangement:

- Engine and generator close coupled together
- Self contained with mounted radiator, exhaust & controls

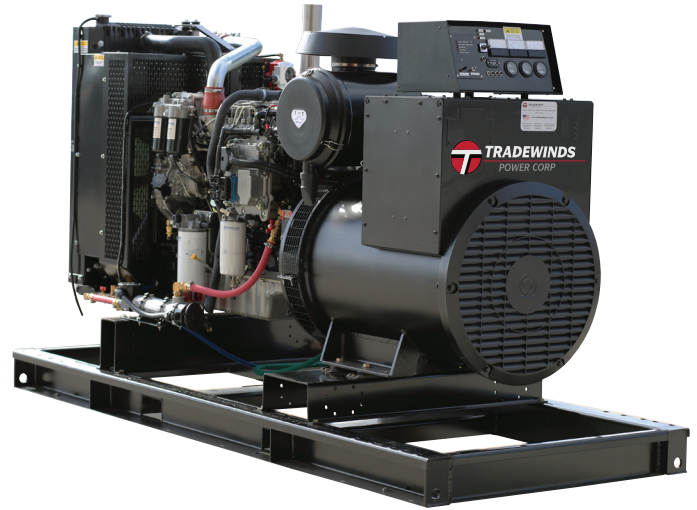

MODEL DEPICTED: TP175P

OPTIONAL ACCESSORIES:

- Above ground fuel tank
- Feed and return fuel lines
- Battery heater
- AC alternator strip heater
- Generator main line circuit breaker
- Thomson automatic transfer switch

AUTOMATIC ENGINE CONTROLLER:

- Automatic engine controller with analog display of all functions
- Manual emergency toggle switch override, to enable the set to be started quickly in the manual position in case of control panel failure
- Metering for AC voltmeter, AC frequency, percentage of load, and hour meter



ANALOG CONTROL PANEL

WARRANTY:

- Engine covered under the original equipment manufacturer's warranty - consult Tradewinds Power Corp for details
- Complete package supplied with 2-year unlimited warranty

The manufacture reserves the right to change the design or specifications without notice and without any obligation or liability whatsoever.

ENGINE SPECIFICATION:	
Manufacturer	Perkins
Model	1104D-E44TAG2
Emissions	EPA Tier 3
Engine speed (rpm)	1800
Nominal Engine hp 1800rpm	148.8
Cylinder arrangement	Vertical, in-line
Combustion system	Direct Injection
Aspiration	Turbo air-to-air charge cooled
Engine type	Diesel
Diesel Fuel Grade	ASTM D975 D2
Number of Cylinders	4
Displacement in ³ (liters)	269 (4.41)
Bore and Stroke inches (mm)	4.1 x 5 (105 X 127)
Cooling	Water-cooled
Governor	Electronic
Starting aids	Glow Plugs
Compression ratio	16.2:1
Air cleaner type	Medium duty dry type
Exhaust Silencer dBA	80dBA
Fuel Filter	Full flow with water separator
COOLING SYSTEM FOR OPERATING AT 120° AMBIENT:	
Cooling System	Water-cooled
Engine Coolant Capacity gals (Liters)	4.49 (17.0)
Fan	Belt driven pusher fan
Radiator	Engine mounted
Coolant grade	TBA
LUBRICATING SYSTEM:	
Total lubricating capacity gals (Liter)	2.1 (8.0)
Recommended lubricating oil grade	SAE 15W40
Oil consumption at full load	< 0.1% of fuel consumption
Maximum Allowable Oil Temperature F (C)	250 (121)

ALTERNATOR:	
Configuration	Brushless, 4-wire
Frequency	60 Hz
Voltage regulation	+ or - 5%
Phase	Single
Coupling	Flexible half coupling
Bearing	Single
Manufacturer	Marathon
Model	TBA
Voltage Configuration	120/240
ARRANGEMENT:	
Coupling	Flexible half coupling
Assembly	Close coupled to flywheel flange
Base arrangement	Rigid steel base frame
Lifting capacity	4-lifting eyes
FUEL CONSUMPTION: GALS/HOUR (LITER/HOUR)	
Standby	7.93 (30.0)
Prime Power	7.29 (27.7)
75%	5.81 (22.0)
50%	4.23 (16.0)
25%	TBA
ENGINE ELECTRICAL SYSTEM:	
Starting motor voltage	12 volt
Charger	65 A Alternator with DC output
Wet Cell Battery	Lead Acid
ANALOG CONTROL PANEL:	
Analog controls	Auto/Stop/Run/Manual
Manual emergency run switch	Override toggle switch to start
Instrumentation	AC Voltmeter
	AC Frequency Meter
	Percentage of Load
	Hour Meter

KEY DIMENSIONS AND WEIGHT		
Description	Key	Inches
Height	H	54.54
Length	L	84.09
Width	W	39.44
Dry Weight lbs (Kg)		1738 (790)

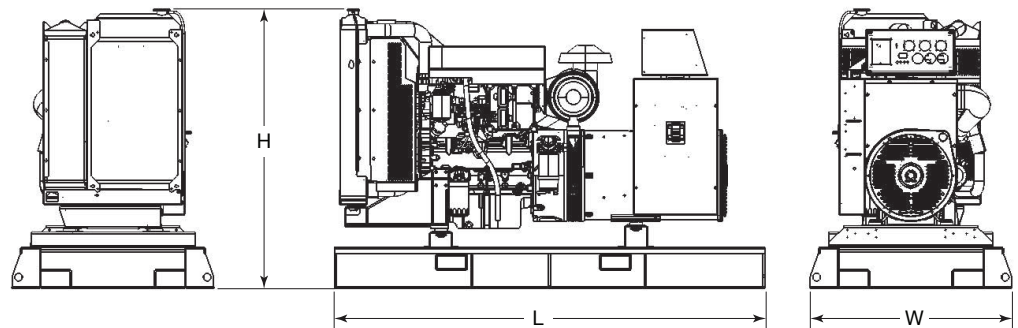
ARRANGEMENT DRAWING MODEL:
 TP100P

TRADEWINDS POWER CORP
 5820 NW 84th Ave
 Miami, FL 33166
 Office: (800) 223-3289