

# SPECIFICATION SHEET

Fuel	Rating	kW	kVA
DIESEL	Intermittent	200.0	250.0
	Continuous	180	225.0
Amperage	208 volt	695 (Standby)	
12-wire voltages: 1P = 120/240; 3P = 120/208, 120/240, 480/277			

**Rating Definitions: Rated for 1800 rpm.**

Standby ratings are applicable for the duration of any power outage. No overload is available at these ratings. Prime ratings are continuous per BS 5514, DIN 6271, ISO3046 & IEC 34-1. Overload capacity on prime-power ratings is 10% for one hour in each twelve hours of operation. All single phase ratings are based on a 1.0 power factor, three (3) phase ratings based on a 0.8 power factor. Ratings are established based on 85°F (29°C) and an elevation of 1,000 feet (305 meters).

**STANDARD FEATURES:**

Tradewinds Power Corp Total PAC is an UL2200 approved completely self contained standby generators packages complete with mounted transfer switch, base fuel tanks, utility and service outlet distribution panels. All our systems and components are prototyped, assembled and tested within a purpose built packaging, manufacturing, and test facility.

**Engine:**

- Perkins 1106D-E70TAG5 diesel engine
- Heavy duty rated for continuous prime power operation
- Cooling system capable of operation at 120°F ambient
- The 1106D utilizes the latest diesel mechanical controlled fuel system technology. This allows the 1106D-E70TAG5 to deliver high power density and excellent fuel economy with low exhaust emissions and minimum heat rejection
- The 1106D has been designed to be worldwide fuel tolerant, and 5% bio-fuel (RME) options are available to meet local market needs
- Mounted air filter and turbocharger
- Wet cast iron sump with filler and dipstick
- Thermostatically controlled jacket water heater

**Alternator:**

- Marathon 4-pole, 12-wire brushless generator, single bearing
- Alternators are oversized with volts per hertz tracking with PMG for enhanced motor starting for engineers to standard on one package
- Superior voltage waveform achieved by a 2/3 pitch and skewed rotor.
- Vacuum-impregnated windings with fungus-resistant epoxy for dependability and long-life
- Sustained short-circuit capability enabling down-line circuit breakers to trip without collapsing the generator field

**Starting System:**

- 12-VDC Starter
- Engine mounted Battery Charging Alternator
- Battery Cables and Rack along with Grounding Strap

**Enclosure and Arrangement of Complete Assembly:**

- Engine and generator close coupled mounted on vibration isolators
- Weather Protective Enclosure constructed of Marine Grade Aluminum 0.125 thickness, SS Hardware, white powder coat paint finish on both sides, sound Insulation resistant to high temperatures, fuel and oil hinged / removable / keyed alike doors
- Residential rated interior mounted exhaust silencer kit
- Vertical radiator and exhaust discharge
- Oil & Coolant Drain Lines with Brass Ball Check Valves
- UL 142 Fuel Tank, sub base mounted, double wall, Carbon steel constructed, with normal and emergency vents; Fuel sender, fuel filler neck with manual gauge.
- 175mph wind load rating

## TOTAL-PAC UL2200 STANDBY SYSTEMS

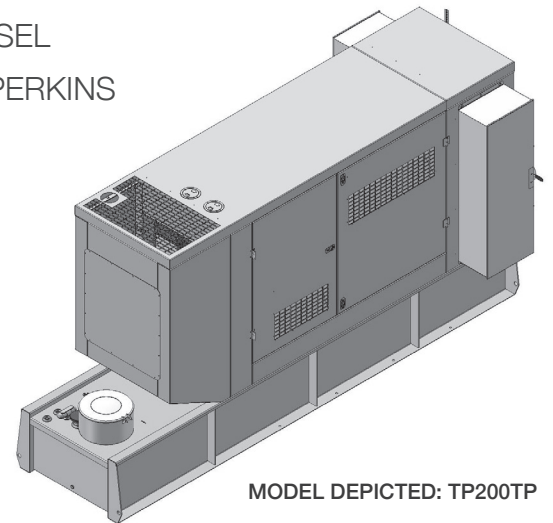
**FUEL: DIESEL**
**ENGINE: PERKINS**

**MODEL DEPICTED: TP200TP**
**AUTOMATIC ENGINE CONTROLLER DGC2020:**

- Automatic engine controller with analog display of all functions
- Microprocessor Based, Navigation key with large LCD display
- SAE J1939 CANBUS Communication
- Event Recording
- Transfer Switch Control (main failures)
- Alternator Protection: under/over voltage, under/over frequency
- Engine Protection: Low oil pressure, High coolant temperature, Over speed & over crank, Sender Unit failure, Fuel Leak / Fuel sender Failure, Battery Charger Failure
- All protections are programmable as Alarms or Pre-alarms
- Metering ( ample range ): Volts, Current, Hz, Watts, VA, Pf, Oil Pressure, Coolant Temperature, RPM, DC Volts, Fuel Level, Engine running time
- Engine Control with Timers
- External remote start input (on or off load)
- 16 programmable contact inputs - 7 Contact outputs

**SCADA interface points:**

- Load fuel
- Low battery charging voltage
- Engine running
- Common engine alarm
- Switch in Emergency Position

**DGC-2020 DIGITAL CONTROLLER**
**OPTIONAL EQUIPMENT:**

- NEMA 4X disconnect boxes
- Low coolant level switch
- Water separator fuel filter
- Space heater
- Generator drip covers
- 17-light remote annunciator panel
- Anti-spill containment (FDEP package) for fuel tanks

**WARRANTY:**

- Complete package supplied with 2-year unlimited warranty
- TPC gives customers the facility to service non-propriety equipment directly, even within the warranty period with a TPC approval #

*The manufacture reserves the right to change the design or specifications without notice and without any obligation or liability whatsoever.*

**TOTAL-PAC UL2000 STANDBY GENERATORS**

ENGINE SPECIFICATION:	
Manufacturer	Perkins
Model	1106D-E70TAG5
Emissions	EPA Tier 3
Engine speed (rpm)	1800
Nominal Engine hp 1800rpm	306
Cylinder arrangement	Vertical, in-line
Combustion system	Direct Injection
Aspiration	Turbocharged aftercooled
Engine type	Diesel
Diesel Fuel Grade	ASTM D975 D2
Number of Cylinders	4
Displacement in <sup>3</sup> (liters)	428 (7.01)
Bore and Stroke inches (mm)	4.13 x 5.31 (105 X 135)
Cooling	Water-cooled
Governor	Electronic
Starting aids	Glow Plugs
Compression ratio	16.8:1
Air cleaner type	Medium duty dry type
Exhaust Silencer dBA	80dBA
Fuel Filter	Full flow with water separator
COOLING SYSTEM FOR OPERATING AT 120°F AMBIENT:	
Cooling System	Water-cooled
Engine Coolant Capacity gals (Liters)	5.5 (21.0)
Fan	Belt driven pusher fan
Radiator	Engine mounted
Coolant grade	TBA
LUBRICATING SYSTEM:	
Total lubricating capacity gals (Liter)	4.36 (16.5)
Recommended lubricating oil grade	SAE 15W40
Oil consumption at full load	< 0.1% of fuel consumption
Maximum Allowable Oil Temperature F (C)	250 (121)
ENCLOSURE AND ARRANGEMENT OF COMPLETE ASSEMBLY:	
Coupling	Close coupled to flywheel flange
Enclosure	Aluminum for weather protection
Base arrangement	Rigid steel base frame with AVMs
Fuel Tank with full spill containment	UL double wall base mounted

ENGINE ELECTRICAL SYSTEM:	
Starting motor voltage	12 volt
Charger	65 A Alternator with DC output
Wet Cell Battery	Lead Acid
ALTERNATOR:	
Configuration	Brushless, 12-wire, 4-pole
Frequency	60 Hz
Voltage regulation	+ / - 1%, V/Hz, Electronic, EMI filtered
No load to full load voltage regulation	+/- 2%.
Coupling	SAE Adapter, Flexible Disc, Direct
Bearing	Single
Manufacturer	Marathon
Model	TBA
Load acceptance	One Step, 100% per NFPA 110
Compliance	NEMA, IEEE & ANSI for temp. rise
Construction	Self ventilated drip-proof
FUEL CONSUMPTION: Gals/Hour (Liters/hour)	
Standby	15.61 (59.1)
Prime Power	14.37 (54.4)
75%	11.49 (43.5)
50%	7.79 (29.5)
25%	4.46 (16.0)
TRANSFER SWITCH:	
Amperage	700A
Integrated Automatic Transfer switch, UL1008, rear side mounted; ATC300 digital controller; Double throw, mechanically interlocked transfer mechanism. Auxiliary relay contacts; Switch position indication contacts; Under/ Over Voltage & Frequency; 3Ph rotation protection, voltage unbalance/loss; Pre transfer signal contact; Seven field programmable time delays; Plant exerciser; System test push button	
CONTROL PANEL SPECIFICATIONS:	
Model	DGC2020
Microprocessor based	Navigation key & large LCD display
Operating power	Nominal 12-24 VDC
Consumption	14.2W run mode
Remote communication capability	Optional
UTILITY AND LOAD CONNECTION PANELS:	
Load Service Disconnect	UL rated Nema3R box
Utility Service Disconnect	UL rated Nema3R box

**DIMENSIONS & ARRANGEMENT DRAWING MODEL: TP200TP**

KEY DIMENSIONS AND WEIGHT		
Description	Key	Inches
Height	H	91.92
Length	L	184.00
Width	W	58.10
Dry Weight lbs (Kg)		6533 (2970)

