

SINGLE ENGINE CLUTCH DRIVE OPU
FUEL: Diesel

ENGINE: John Deere

SPECIFICATION SHEET

Fuel	Rating	Intermittent	Continuous
Diesel	Max. power: hp (kW)	185 (138)	166 (124)
	hp @ 1800 rpm hp (kW)	161 (1120)	145 (108)
	Torque: ft-lb (N-m) rpm	484 @1400 rpm	

Rating Definitions: The Industrial Continuous engine power rating is for applications that operate with constant load and speed, except for short periods during startup or shutdown. Power output is within + or - 5% at standard SAE J 1995 and ISO3046. (See power curves over)

STANDARD FEATURES:

Tradewinds Power Corp open engine power units are designed, packaged, and tested to meet the power requirements of a wide range of equipment used in agricultural applications. All our systems and components are prototyped, assembled and tested within a purpose built packaging, manufacturing, and test facility.

Key System Features are:

- Engine power units will accept one-step loading
- Emissions comply with non-regulated markets
- EPA Tier 1 for compact economic power
- Complete package ready to use in all Ag applications
- Self contained with mounted exhaust and air-cleaner
- TPC Analog controller for engine start and stop
- Low oil pressure and high engine temperature fault detection and shut-down protection

Engine:

- John Deere 6068TF250 industrial diesel engine
- Heavy duty rated for continuous prime power operation
- Cooling system capable of operation at 120°F ambient
- Cross flow head design that provides excellent breathing from a lower cost two-valve cylinder head
- Mechanical rotary fuel pump. The timing and fuel injection pressures are optimized to maximize performance and fuel economy at a given rated speed
- When fitted fixed geometry turbochargers are sized for a specific power range and optimized to provide excellent performance across the entire torque curve. They are also designed to maximize fuel economy between the engine's rated speed and peak torque
- Turbo-charged aspirated engine
- Self-adjusting poly-vee fan drive
- 500-hour oil change interval
- Replaceable wet-type cylinder liners

Drive System:

- SAE coupled and/or PTO Clutch directly mounted to flywheel housing

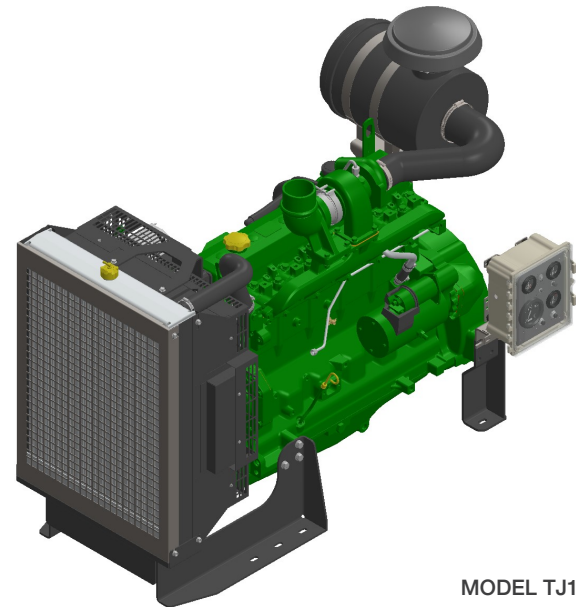
MODEL TJ185-24T11
Engine Power Unit Arrangement:

- IOPU completely assembled from Radiator through Flywheel
- Mounted exhaust, radiator, and air cleaner
- All rotating surfaces protected with guards

AUTOMATIC ENGINE CONTROLLER:

- CAN-based display with rich, full-color graphics
- Full engine control and safety shut-down monitoring
- Bonded glare-free LCD screen, viewable in direct sunlight
- Easy -to-use configuration software
- Full autostart, manual start, and off controls
- Rugged design for extreme environments

**ML1000-4X
ENGINE CONTROLLER**
WARRANTY:

- Engine covered under the original equipment manufacturer's warranty - consult Tradewinds Power Corp for details
- Complete package supplied with one-year limited warranty

The manufacture reserves the right to change the design or specifications without notice and without any obligation or liability whatsoever.

DRIVE ASSEMBLY:

Configuration	Single engine 1800 rpm clutch drive
Clutch manufacturer	Tradewinds
Operation	Manual
Pulley drive arrangement	N.A.
Drive shaft speed rpm	1800
Bearings	N.A.

ENGINE SPECIFICATION:

Manufacturer	John Deere
Model	6068TF250
Emissions	EPA Tier1
Continuous HP @ 1800 rpm	145
Engine Type	In-line, 4-cycle
Combustion system	Compression
Aspiration	Turbocharged
Engine type	Diesel Injection
Diesel fuel grade	ASTM D975 D2
Number of cylinders	6
Displacement in ³ (liters)	414 (6.8)
Bore and stroke ins (mm)	4.19 X 5.00 (106 X 127)
Peak power hp (kW) @ 2400 rpm	185 (138)
Cooling	Liquid
Governor	Engine Control Unit ECU
Compression ratio	17.0:1
Air cleaner type	Canister air cleaner
Exhaust Silencer dBA	TBA
Max. exh temp at full load degrees °F (°C)	TBA
Max. back pressure - ins H ₂ O (kPa)	30 (7.5)
Fuel filter	Full flow with water separator

COOLING SYSTEM FOR OPERATING AT 120°F AMBIENT:

Coolant flow - gal/min (L/min)	68 (228)
Radiator Capacity gallons (Liters)	TBA

LUBRICATION SYSTEM:

Oil pan capacity with filter - quarts	TBA
Recommended lubricating oil grade	15W 40
Oil consumption at full load	< 0.1% of fuel consumption
Oil pressure - psi (kPa)	46 (320)

ENGINE ELECTRICAL SYSTEM:

Starting motor voltage	12 volt
Wet cell battery	Lead Acid
Cold cranking amps - minimum	720 amps

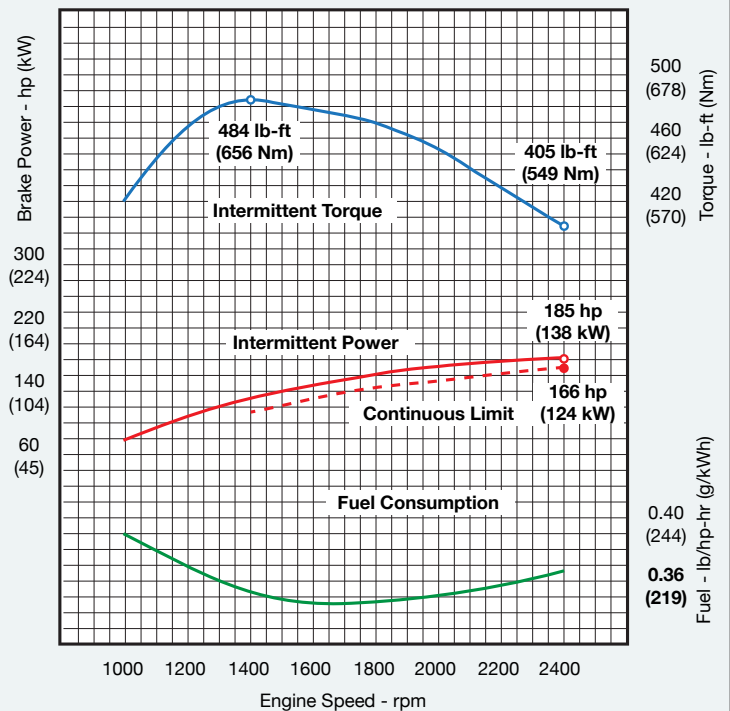
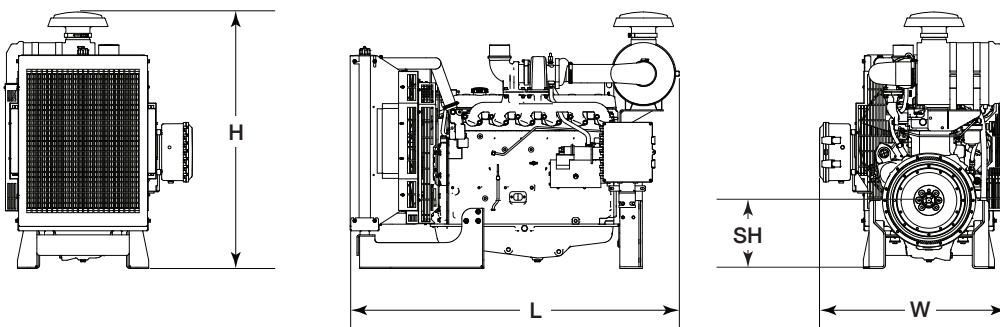
Performance Curves 6068TF250 - 185 hp

**ARRANGEMENT DRAWING MODEL:
TJ185-24T1I OPU**

KEY DIMENSIONS AND WEIGHT

Description	Key	Inches
Height	H	48.96
Length	L	55.79
Width	W	35.00
Shaft Height	SH	13.00
Dry Weight lbs (Kg)		1863.3 (842.4)

TRADEWINDS POWER CORP

5820 NW 84Th Avenue
 Miami
 Florida 33166
 Call: 800.223.3289