

**SINGLE ENGINE CLUTCH DRIVE OPU**
**FUEL:** Diesel

**ENGINE:** John Deere

**SPECIFICATION SHEET**

Fuel	Rating	Intermittent	Continuous
Diesel	Max. power: hp (kW)	80.0 (59.7)	72.0 (53.7)
	hp @ 1800 rpm hp (kW)	68.8 (51.2)	62.0 (46.3)
	Torque: ft-lb (N-m) rpm	214-223 (290-302) @1000-1200 rpm	

**Rating Definitions:** The Industrial Continuous engine power rating is for applications that operate with constant load and speed, except for short periods during startup or shutdown. Power output is within + or - 5% at standard SAE J 1995 and ISO3046. (See power curves over)

**STANDARD FEATURES:**

Tradewinds Power Corp open engine power units are designed, packaged, and tested to meet the power requirements of a wide range of equipment used in agricultural applications. All our systems and components are prototyped, assembled and tested within a purpose built packaging, manufacturing, and test facility.

**Key System Features are:**

- Engine power units will accept one-step loading
- Emissions comply with non-regulated markets
- EPA Tier 1 for compact economic power
- Complete package ready to use in all Ag applications
- Self contained with mounted exhaust and air-cleaner
- TPC Analog controller for engine start and stop
- Low oil pressure and high engine temperature fault detection and shut-down protection

**Engine:**

- John Deere 4045DF150 industrial diesel engine
- Heavy duty rated for continuous prime power operation
- Cooling system capable of operation at 120°F ambient
- Cross flow head design that provides excellent breathing from a lower cost two-valve cylinder head
- Mechanical rotary fuel pump. The timing and fuel injection pressures are optimized to maximize performance and fuel economy at a given rated speed
- When fitted fixed geometry turbochargers are sized for a specific power range and optimized to provide excellent performance across the entire torque curve. They are also designed to maximize fuel economy between the engine's rated speed and peak torque
- Naturally aspirated engine
- Self-adjusting poly-vee fan drive
- 500-hour oil change interval
- Replaceable wet-type cylinder liners

**Drive System:**

- SAE coupled and/or PTO Clutch directly mounted to flywheel housing

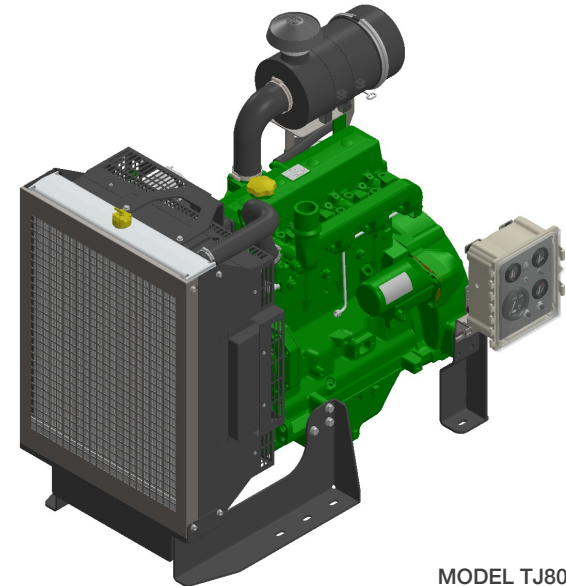
**MODEL TJ80-24T11**
**Engine Power Unit Arrangement:**

- IOPU completely assembled from Radiator through Flywheel
- Mounted exhaust, radiator, and air cleaner
- All rotating surfaces protected with guards

**AUTOMATIC ENGINE CONTROLLER:**

- CAN-based display with rich, full-color graphics
- Full engine control and safety shut-down monitoring
- Bonded glare-free LCD screen, viewable in direct sunlight
- Easy -to-use configuration software
- Full autostart, manual start, and off controls
- Rugged design for extreme environments

**ML1000-4X  
ENGINE CONTROLLER**
**WARRANTY:**

- Engine covered under the original equipment manufacturer's warranty - consult Tradewinds Power Corp for details
- Complete package supplied with one-year limited warranty

*The manufacture reserves the right to change the design or specifications without notice and without any obligation or liability whatsoever.*

**SINGLE ENGINE CLUTCH DRIVE OPU**
**FUEL:** Diesel

**ENGINE:** John Deere

**DRIVE ASSEMBLY:**

Configuration	Single engine 1800 rpm clutch drive
Clutch manufacturer	Tradewinds
Operation	Manual
Pulley drive arrangement	N.A.
Drive shaft speed rpm	1800
Bearings	N.A.

**ENGINE SPECIFICATION:**

Manufacturer	John Deere
Model	4045DF150
Emissions	EPA Interim Tier 1
Continuous HP @ 1800 rpm	62
Engine Type	In-line, 4-cycle
Combustion system	Compression
Aspiration	Naturally Aspirated
Engine type	Diesel Injection
Diesel fuel grade	ASTM D975 D2
Number of cylinders	4
Displacement in <sup>3</sup> (liters)	276 (4.5)
Bore and stroke ins (mm)	4.19 X 5.00 (106 X 127)
Peak power hp (kW) @ 2500rpm	80.0 (59.7)
Cooling	Liquid
Governor	Mechanical
Compression ratio	17.6:1
Air cleaner type	Canister air cleaner
Exhaust Silencer dBA	TBA
Max. exh temp at full load degrees °F (°C)	1080 (582)
Max. back pressure - ins H <sub>2</sub> O (kPa)	30 (7.5)
Fuel filter	Full flow with water separator

**COOLING SYSTEM FOR OPERATING AT 120°F AMBIENT:**

Coolant flow - gal/min (L/min)	54 (204)
Radiator Capacity gallons (Liters)	TBA

**LUBRICATION SYSTEM:**

Oil pan capacity with filter - quarts	TBA
Recommended lubricating oil grade	15W 40
Oil consumption at full load	< 0.1% of fuel consumption
Oil pressure - psi (kPa)	46 (320)

**ENGINE ELECTRICAL SYSTEM:**

Starting motor voltage	12 volt
Wet cell battery	Lead Acid
Cold cranking amps - minimum	720 amps

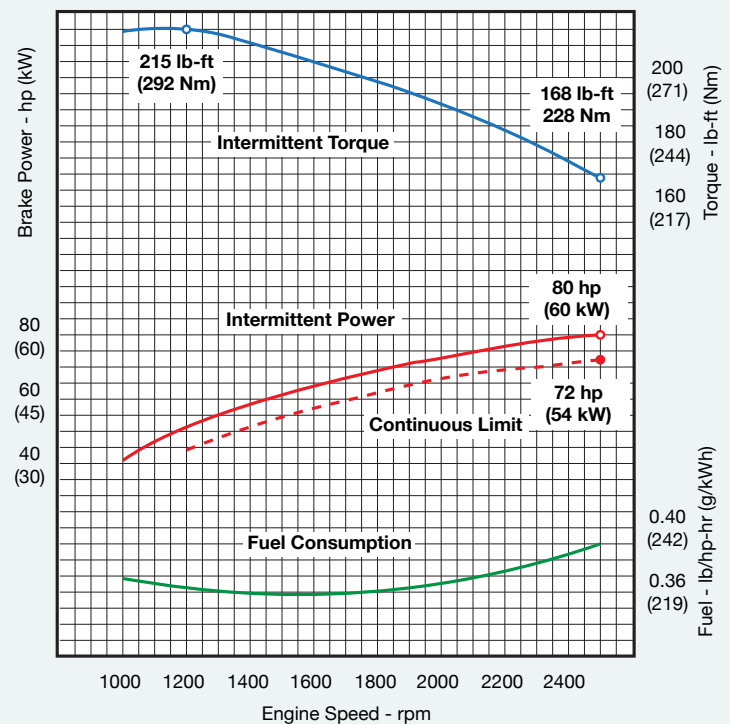
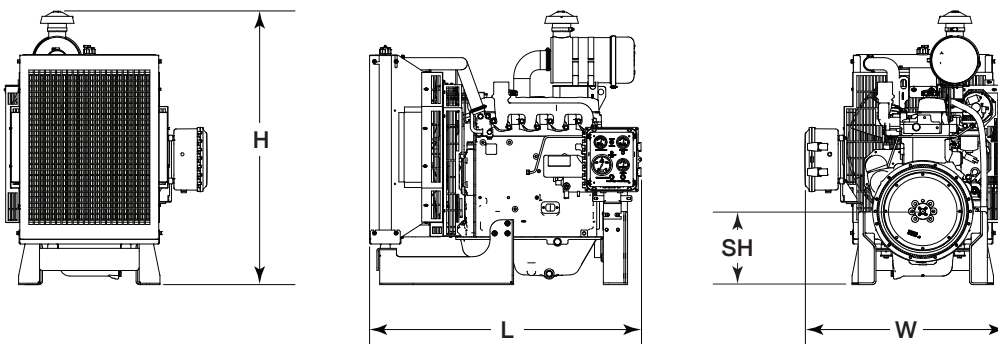
**Performance Curves 4045DF150 - 80 hp**

**ARRANGEMENT DRAWING MODEL:  
TJ80-25T11 OPU**

**KEY DIMENSIONS AND WEIGHT**

Description	Key	Inches
Height	H	48.47
Length	L	45.71
Width	W	35.00
Shaft Height	SH	13.00
Dry Weight lbs (Kg)		1476.6 (671.2)

**TRADEWINDS POWER CORP**

 5820 NW 84Th Avenue  
 Miami  
 Florida 33166  
 Call: 800.223.3289