

SPECIFICATION SHEET

Fuel	Rating	Intermittent	Continuous
Diesel	Power: hp (kW) 2000rpm	261.4 (195)	235.3 (175.5)
	Torque: ft-lb (N-m) 1400rpm	774.4 (1050)	697 (945)
	Power: hp (kW) 1800rpm	249.4 (186)	224.3 (167.4)

Rating Definitions: Intermittent is the horsepower and speed capability of the engine where maximum power and/or speed are cyclic (time at full load not to exceed 50%). The Industrial Continuous engine power rating is for applications that operate with constant load and speed, except for short periods during startup or shutdown. Power output is within + or - 5% at standard SAE J 1995 and ISO3046. (See power curves over)

STANDARD FEATURES:

Tradewinds Power Corp open engine power units are designed, packaged, and tested to meet the power requirements of a wide range of equipment used in agricultural applications. All our systems and components are prototyped, assembled and tested within a purpose built packaging, manufacturing, and test facility.

Key System Features are:

- Engine power units will accept one-step loading
- EPA and CARB certified for Agricultural use
- Designed to meet 2012 EPA Tier 4 Interim
- Complete package ready to use in all Ag applications
- Self contained with mounted exhaust and air-cleaner
- MPC Controller for engine start and stop
- Low oil pressure and high engine temperature fault detection and shut-down protection

Engine:

- Perkins 1106D.E70TA industrial diesel engine
- Heavy duty rated for continuous prime power operation
- Cooling system capable of operation at 120°F ambient
- Fuel system is common rail fuel pump and injectors
- A robust electronically controlled common rail engine provides the opportunity to increase power and low speed torque
- The ECM (Electronic Control Module) controls the injection timing through all speeds and loads. The ECM includes sensors for engine speed, oil pressure, and coolant temperature
- Turbo charged for greater engine output
- The engines are designed and built for dependability and durability, which results in minimum maintenance requirements
- Low cost maintenance is achieved through hydraulic tappets, multi-vee belts and 500 hour oil change intervals
- Design consideration has also been incorporated to facilitate the next emissions change to EU Stage IIIB / EPA Tier 4

Drive System:

- Clutch directly mounted to flywheel housing
- Twin Disc clutch

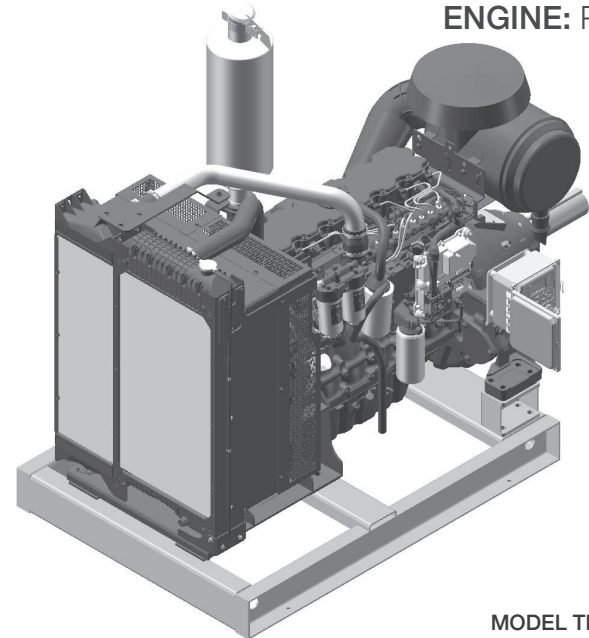

MODEL TP250-I

Engine Power Unit Arrangement:

- Engine OPU assembly mounted on steel frame
- Mounted exhaust, radiator, and air cleaner
- All rotating surfaces protected with guards
- Oil and water drain lines.

AUTOMATIC ENGINE CONTROLLER:

- Automatic engine controller with digital display of all functions
- Quick and easy to install
- Advanced, rugged, reliable microprocessor-based design
- Full engine monitoring and shut down protection
- Full autostart, manual start, and off controls
- 3.8" monochrome, transfective, white backlight LCD

 MPC-20
 ENGINE CONTROLLER
 (Available on remote stand)

WARRANTY:

- Engine covered under the original equipment manufacturer's warranty - consult Tradewinds Power Corp for details
- Complete package supplied with one-year unlimited warranty

The manufacture reserves the right to change the design or specifications without notice and without any obligation or liability whatsoever.

SINGLE ENGINE CLUTCH DRIVE OPU
FUEL: Diesel

ENGINE: Perkins

DRIVE ASSEMBLY:	
Configuration	Single engine 1800 rpm clutch drive
Clutch manufacture	Twin Disc
Operation	Manual
Pulley drive arrangement	N.A.
Drive shaft speed rpm	1800
Bearings	N.A.
ENGINE SPECIFICATION:	
Manufacturer	Perkins
Model	1106D.E70TA
Emissions	U.S. EPA Tier 3
Crankshaft speed	2,200 rpm
Engine Type	In-line, 4-cycle
Combustion system	Compression
Aspiration	Turbocharged aftercooled
Engine type	Diesel Injection
Diesel fuel grade	ASTM D975 D2
Number of cylinders	6
Displacement in ³ (liters)	428 (7.1)
Bore and stroke ins (mm)	4.13 X 5.3 (105 X 135)
Peak power hp (kW) @ 2200rpm	261.4 (195)
Cooling	Liquid
Governor	Electronic ECU
Compression ratio	16.8:1
Air cleaner type	Canister air cleaner
Exhaust Silencer dBA	TBA
Max. exh temp at full load degrees °F (°C)	TBA
Max. back pressure - ins H ₂ O (kPA)	TBA
Fuel filter	Full flow with water separator
COOLING SYSTEM FOR OPERATING AT 120°F AMBIENT:	
Eng. Cooling air flow - ft ³ /sec (m ³ /sec)	TBA
Radiator Capacity gallons (Liters)	4.0 (15.2)

LUBRICATION SYSTEM:	
Oil pan capacity with filter - quarts (Liters)	4.2 (16.0)
Recommended lubricating oil grade	15W 40
Oil consumption at full load	< 0.1% of fuel consumption
Oil pressure - psi (kPA)	46 (320)
ENGINE ELECTRICAL SYSTEM:	
Starting motor voltage	12 volt
Wet cell battery	Lead Acid
Cold cranking amps - minimum	720 amps

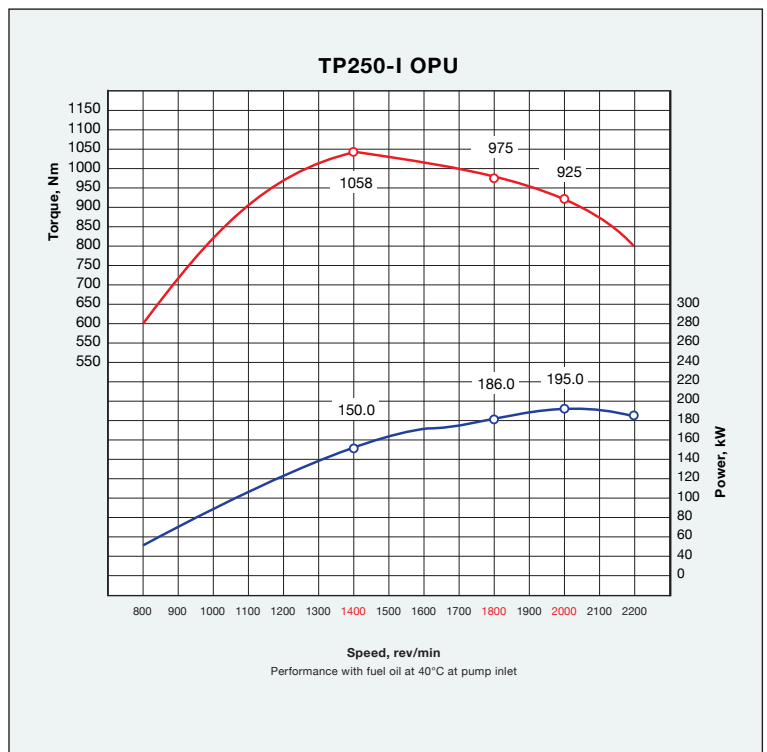
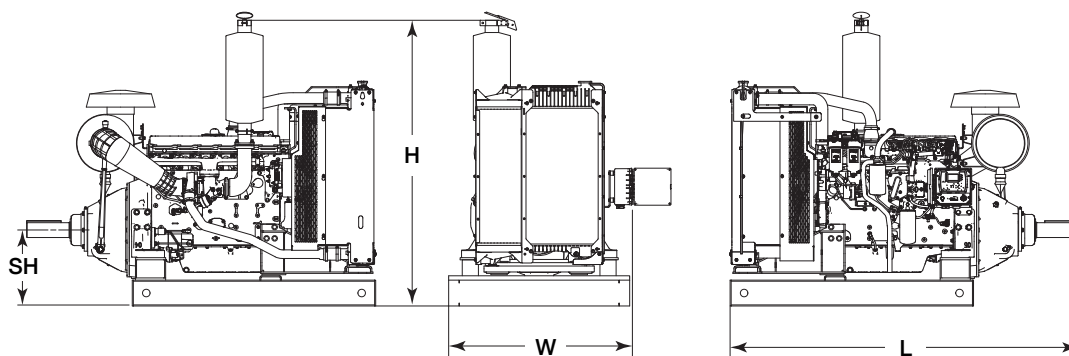
POWER & TORQUE CURVES

**ARRANGEMENT DRAWING MODEL:
TP250-I OPU Clutch Drive**

KEY DIMENSIONS AND WEIGHT

Description	Key	Inches
Height	H	66.3
Length	L	81.02
Width	W	42
Shaft Height	SH	17.62
Dry Weight lbs (Kg)		2312 (1051)

TRADEWINDS POWER CORP

 600 State Road 66
 Sebring
 Florida 33875
 Call: 800.206.2224